

Fieldbus Temperature Transmitters Model T53.10, for FOUNDATION™ Fieldbus and PROFIBUS® PA

WIKA Data Sheet TE 53.01



Applications

- Process industry
- Machine building and plant construction

Special Features

- FOUNDATION™ Fieldbus ITK Version 4.61
- PROFIBUS® PA Profile 3
- Automatic switch between protocols
- Explosion protection, EEx i, intrinsically safe / FISCO
- Explosion protection, EEx n



Fieldbus Temperature Transmitter, Model T53.10.01S

Description

The Fieldbus temperature transmitter Model T53.10 with FOUNDATION™ and PROFIBUS® PA Fieldbus Communication is suitable for temperature measurement with resistance thermometers and thermocouples. Furthermore resistance and mV measurements with or without customer specific linearisation are possible. Difference, average or redundancy temperature measurements can be realised.

The T53 is available at FOUNDATION™ Fieldbus with LAS-Functionality (Link Active Scheduler) and PID-Regulation. These functionalities allow for Master-independent regulations in the field housing.

The Fieldbus temperature transmitter Model T53.10 has a polarity-independent bus connection. Due to its small dimensions the temperature transmitter is suitable for all DIN Form B connection heads.

Delivered with a basic configuration (according to the ordering options) or customer specific configuration in line with the configuration options.

Specifications		Model T53.10						
Input	configurable	Sensor				Measuring range		Standard
Resistance thermometers		Pt25 ... Pt1000 ($\alpha = 0.00385$)		-200 °C ... +850 °C		IEC 60 751		
		Pt25 ... Pt1000 ($\alpha = 0.003916$)		-200 °C ... +850 °C		JIS C1604 (1989)		
		Ni25 ... Cu1000		-60 °C ... +250 °C		DIN 43 760		
Thermocouples		Cu10 ... Cu1000		-50 °C ... +200 °C		$\alpha = 0.00427$		
		B		+400 °C ... +1820 °C		IEC 584		
		E		-100 °C ... +1000 °C		IEC 584		
		J		-100 °C ... +1200 °C		IEC 584		
		K		-180 °C ... +1372 °C		IEC 584		
		L		-200 °C ... +900 °C		DIN 43 710		
		N		-180 °C ... +1300 °C		IEC 584		
		R		-50 °C ... +1760 °C		IEC 584		
		S		-50 °C ... +1760 °C		IEC 584		
		T		-200 °C ... +400 °C		IEC 584		
		U		-200 °C ... +600 °C		DIN 43 710		
		W3		0 °C ... +2300 °C		ASTM E988-90		
		W5		0 °C ... +2300 °C		ASTM E988-90		
External CJC (cold junction compensation)		-40 °C ... +135 °C						
Resistance sensor		0 ... 10 k Ω						
Potentiometric resistance sensor		0 ... 100 k Ω						
mV-sensor		-800 ... +800 mV						
Basic configuration		Pt100, 3-wire 0 °C ... 100 °C						
Sensor current		typically 0.2 mA						
Max. cable resistance		50 Ω per wire						
Measuring accuracy, at 24 °C \pm 4 K		Sensor	Base accuracy			Temperature coefficient		
		Pt100 and Pt1000	$\leq \pm 0.1$ °C			$\leq \pm 0.002$ °C / °C		
		Ni100	$\leq \pm 0.15$ °C			$\leq \pm 0.002$ °C / °C		
		Cu10	$\leq \pm 1.3$ °C			$\leq \pm 0.02$ °C / °C		
		Lin. R.	$\leq \pm 0.05$ Ω			$\leq \pm 0.002$ Ω / °C		
		Volt	$\leq \pm 10$ μ V			$\leq \pm 0.2$ μ V / °C		
		TE-Type: E, J, K, L, N, T, U	$\leq \pm 0.5$ °C			$\leq \pm 0.01$ °C / °C		
		TE-Type: B, R, S, W3, W5	$\leq \pm 1$ °C			$\leq \pm 0.025$ °C / °C		
Error cold junction compensation (CJC)		$\leq \pm 0.5$ °C						
Output		FOUNDATION™ Fieldbus		PROFIBUS® PA				
Version		ITK version 4.61		EN 50 170 vol. 2 / profile 3				
Functionality		Basic or LAS						
Function blocks		2 analogue and 1 PID		2 analogue				
Execution time, PID-controller		< 200 ms						
Power supply								
Supply voltage		9 ... 32 VDC (maximum values specified in the type-examination certificate are to be observed)						
Current consumption		< 11 mA						
Explosion protection		Model T53.10.OIS				Model T53.10.ONI		
Ex-protection (ATEX)		II 1 GD		II 2 (1) GD		Zone 2, category 3G		
Ignition protection type		EEx ia IIC T4/T5/T6 T65 °C ... T105 °C		EEX ib [ia] IIC, T4/T5/T6 T65 °C ... T105 °C		EEx nA[nL] IIC T4/T5/T6		
EC-type examination certificate		KEMA 06 ATEX 0148X				KEMA 06 ATEX 0149X		
FM		IS, Class I, Division 1, Group A, B, C, D Non-Incendive, Class I, Division 2 Group A, B, C, D				Non-Incendive, Class I, Div. 2, Group A, B, C, D		
Installation Drawing		11175631.01				11175631.01		
CSA		IS, Class I, Division 1, Groups A, B, C, D		IS, Class I, Div. 2, Groups A, B, C, D		Non-Incendive, Class I, Div. 2, Group A, B, C, D		
Certificate No.		1807316				1807316		
Maximum values for connection of the current loop circuit		Po	Po	FISCO	FISCO	Po	FISCO	
		< 0.84 W	< 1.3 W			< 5.32 W		
Supply voltage Ui		30 VDC	30 VDC	17.5 VDC	15 VDC	30 VDC	17.5 VDC 32 VDC	
Strength of current Ii		120 mA	300 mA	250 mA	900 mA	250 mA		
Power Pi		0.84 W	1.3 W	2.0 W	5.32 W	5.32 W		
Internal capacitance Ci		2 nF	2 nF	2 nF	2 nF	2 nF	---	
Internal inductance Li		1 μ H	1 μ H	1 μ H	1 μ H	1 μ H	---	
Medium temperature/ Ambient temperature		T4: <85°C T5: <75°C T6: <60°C	T4: <75°C T5: <65°C T6: <45°C	T4: <85°C T5: <60°C T6: <45°C		T4: <85°C T5: <75°C T6: <60°C	T4: <85°C T5: <75°C T6: <60°C	
Maximum values for connection of the sensor circuit								
Supply voltage Uo		5.7 V						
Strength of current Io		8.4 mA						
Power Po		12 mW						
Capacitance Co		40 μ F						
Inductance Lo		200 mH						

Further specifications **Model T53.10**

Electromagnetic compatibility (EMC)	EMC directive 2004/108/EC, EN 61326 Emission (group 1, class B) and immunity (industrial application) and NAMUR NE 21
Ambient conditions	
Ambient and storage temperature	-40 ... +85 °C
Maximum permissible humidity	95 % relative humidity, without condensation
Vibration	2 ... 100 Hz 4 g DIN EN 60 068-2-6
Special features	
Insulation voltage, test / operation	1.5 kVAC / 50 VAC
Response time (programmable)	1 ... 60 s
Updating time	< 400 ms
Execution time, analogue input block	< 50 ms
Case	for head mounting design, incl. spring-loaded mounting screws
Material	Plastic, PBT, glass fibre reinforced
Ingress protection	case IP 68 IEC 529 / EN 60 529
	terminal IP 00 IEC 529 / EN 60 529
Cross section of terminal connectors	0.14 ... 1.5 mm ²
Weight	approx. 0.05 kg

Designation of terminal connectors

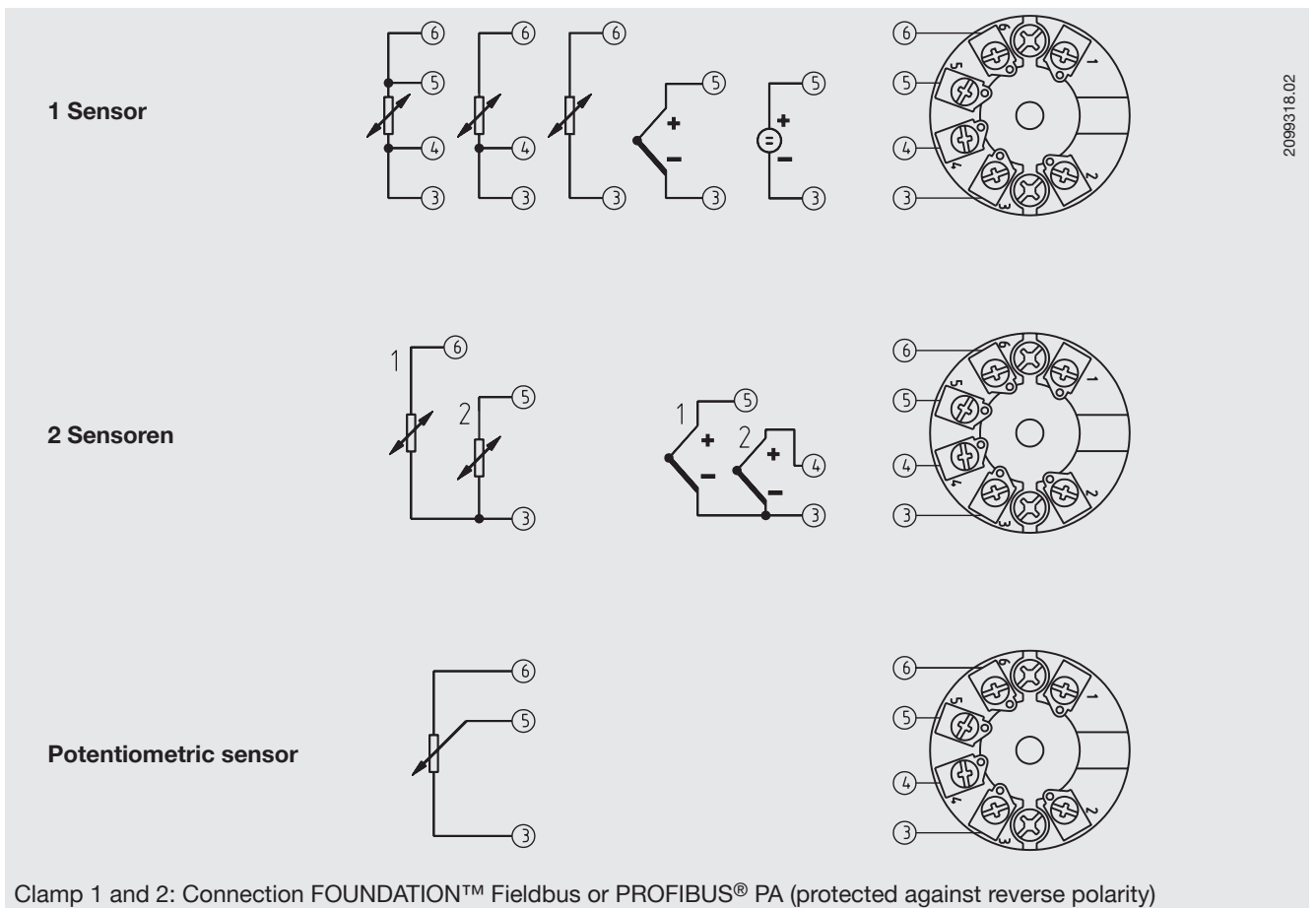

Dimensions in mm

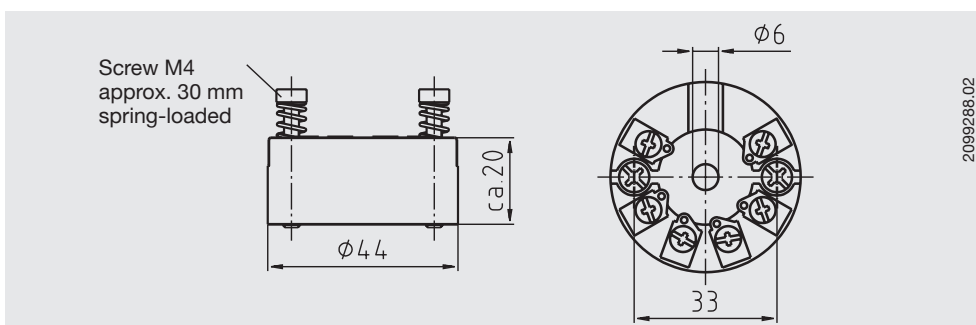

Accessory

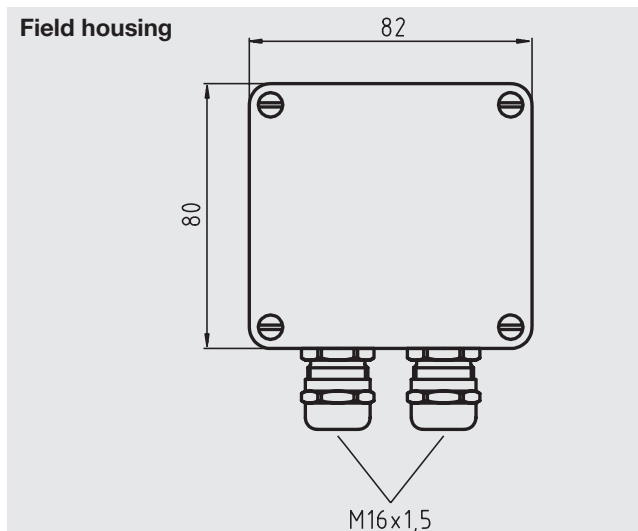

Accessory (please order separately)	Order No.
Field Communicator FC375 English for HART® and FOUNDATION™ fieldbus, ATEX II 2G (1GD) EEx ia IIC T4, FM Class I, Division 1, Groups A, B, C, D T4, CSA Ex ia IIC NiMH battery, with power supply 90 - 240 VAC, with EASY UPGRADE OPTION	2133702
Field housing, plastic (ABS), IP 65, for mounting of a head mounting transmitter, permissible ambient temperature: -40 °C ... +80 °C, 82 x 80 x 55 mm (W x L x H), with two cable glands M16 x 1.5	3301732
Adapter, plastic/stainless steel, for mounting on a DIN rail	3593789
Adapter, steel tin galvanized, for mounting on a DIN rail	3619851

Ordering information

Field No.	Code	Features
Explosion protection		
1	<input type="checkbox"/>	NI II 3G EEx nA [nL] / NI CSA / NI FM for Zone 2 / Div 2
	<input type="checkbox"/>	IS II 1GD EEx ia / IS CSA / IS FM for Zone 0 / Div 1
Measuring range		
2	<input type="checkbox"/>	GK Basic configuration (Pt100, 3-wire, limits for 0 ... 100 °C, busadress 126)
	<input type="checkbox"/>	KK Customer specific configuration please state as additional text
Additional order information		
3	<input type="checkbox"/>	YES NO
	<input type="checkbox"/>	T Z Additional text Please state as clearly understandable text!

Order code:

T53.10 . 0 - -

Additional text:

Modifications may take place and materials specified may be replaced by others without prior notice. Specifications and dimensions given in this leaflet represent the state of engineering at the time of printing.



WIKAI Alexander Wiegand SE & Co. KG
 Alexander-Wiegand-Straße 30
 63911 Klingenberg/Germany
 Tel. (+49) 9372/132-0
 Fax (+49) 9372/132-406
 E-mail info@wika.de
 www.wika.de