

Ultra High Purity Transducer Models WU-10, WU-15 and WU-16 with and without side access

WIKA Datasheet WU-1X

Applications

- Semiconductor and flat panel display industry
- Microelectronics engineering
- Gas distribution systems
(Gas sticks, gas panels, bulk-gas supply)
- Ultra high purity water supply

Special Features

- Thin-film sensor
- Excellent long-term stability
- Exchangeable electronics
- No span adjustment required
- Ingress protection IP 65 / IP 54 with side access

Description

Universal

As a result of its broad pressure range spectrum from vacuum up to 400 bar (5000 psi), its compact design and its excellent performance, model WU-10 offers a perfect combination of an appealing design and proven measuring technology.

Flow through transducers of the WU-15 series have been developed for ultra pure media applications where, apart from the requirement for easy cleaning of the transducer, the application also demands a proven, stable sensor technology. Through the optimised design of the sensor connection, external influences on the sensor signal have been eliminated, even in the case of varying fastening torques of the process connections.

Reliable

Thin-film sensors produced by WIKA have ensured high accuracy, long-term stability and repeatability in industrial pressure measurement instrumentation for decades. We use special thin-film sensors made of 2.4711 / UNSR 30003 in order to meet the particular requirements of the ultra pure media industry.



Fig. left Transducer WU-10, Single End
Fig. center Transducer WU-15, Flow Through
Fig. right Transducer WU-16, Modular Surface Mount

Hermetically welding of the thin-film sensor guarantees a total separation of medium, as well as a long-term high impermeability which is required by the user.

Versatile

The modular design makes it possible to configure a high number of variants in order to comply with the manifold requirements of UHP applications. All wetted parts are electropolished using state-of-the-art equipment prior to the final assembly.

The integrated potentiometer enables adjustment of the zero point up to 5% of the full scale value. An adjustment of span is not required.

Exchangeable electronics enable replacement of the amplifier without disconnecting the sensors from the process. The high ingress protection (NEMA-4) allows operation even under the most difficult conditions.

Specifications

Models WU-10, WU-15, WU-16

		WU-10 / WU-15										
		WU-16										
Pressure ranges	bar	4	7	10	16	25	40	60	100	160	250	400
	psi	60	100	160	250	300	500	1000	1500	2000	3000	5000
Over pressure safety ¹⁾	bar	8	14	20	32	50	80	120	200	320	500	500
Burst pressure ¹⁾	bar	40	70	100	160	250	400	550	720	720	720	720
Other pressure ranges and pressure units (e.g. MPa, kg/cm ²) on request												
¹⁾ 1 bar = 14.50 psi												
Measuring principle		Metal thin film sensor										
Materials												
■ Wetted parts		2.4711 / UNSR 30003 (sensor); 316L VIM/VAR (Process connection)										
■ Case		Stainless steel										
Surface finish		Electropolished, typical Ra ≤ 0.18 µm (RA 7); max. Ra ≤ 0.25 µm (RA 10)										
Dead volume	mm ³	WU-10 < 1500, WU-15 < 1000, WU-16 < 1000										
Permissible Medium		Liquid / Gas / Vapour										
Power supply U _B	U _B in VDC	10 < U _B ≤ 30 (14 ... 30 with output signal 0.1 ... 10.1 V and 0 ... 10 V)										
Capacitive load	µF	Max. 0.1 (Voltage output)										
Max. current consumption	mA	< 1 Voltage output signal; Source										
	mA	< 30 Current output signal										
Adjustability zero	% of span	± 5 via potentiometer										
Response time (10 ... 90 %)	ms	≤ 2										
Dielectric strength	VDC	500										
Accuracy	% of span	≤ 0.25 for pressure ranges > 4 bar (BFSL)										
	% of span	≤ 0.5 for pressure ranges ≤ 4 bar (BFSL)										
	% of span	≤ 0.5 ²⁾ for pressure ranges > 4 bar										
	% of span	≤ 1.0 ²⁾ for pressure ranges ≤ 4 bar										
²⁾ Including non-linearity, hysteresis, zero point and full scale error												
(corresponds to error of measurement per IEC 61298-2).												
Adjusted in vertical mounting position with lower pressure connection.												
Non-linearity	% of span	≤ 0.15 for pressure ranges > 4 bar (BFSL) according to IEC 61298-2										
	% of span	≤ 0.3 for pressure ranges ≤ 4 bar (BFSL) according to IEC 61298-2										
1-year stability	% of span	≤ 0.2 (at reference conditions)										
Permissible temperature of												
■ Medium		-20 ... +100 °C					-4 ... +212 °F					
■ Ambience		-20 ... +85 °C					-4 ... +185 °F					
■ Storage		-40 ... +100 °C					-40 ... +212 °F					
Compensated temp. range		-20 ... +80 °C					-4 ... +176 °F					
Temperature coefficients within compensated temperature range:												
■ mean TC of zero	% of span	≤ 0.1 / 10 K										
■ mean TC of range	% of span	≤ 0.15 / 10 K										
CE-conformity												
Pressure equipment directive		97/23/EG										
■ EMC directive		89/336/EEC emission (class B) and immunity according to EN 61 326										
Shock resistance	g	500 according to IEC 60068-2-27 (mechanical shock)										
Vibration resistance	g	10 according to IEC 60068-2-6 (vibration under resonance)										
Wiring protection												
■ Short-circuit proofness		Sig+ towards UB-										
■ Reverse polarity protection		UB+ towards UB-										
Mass	kg	Approx. 0.1										

Output signal and allowed load

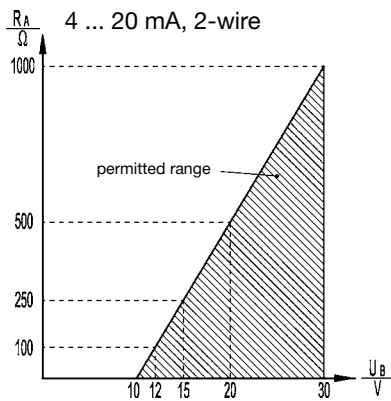

Output current (2-wire)

4 ... 20 mA:

$$R_A \leq (U_B - 10 \text{ V}) / 0.02 \text{ A}$$

Output voltage (3-wire)

0.1 ... 5.1 V: $R_A > 5 \text{ kOhm}$

0.1 ... 10.1 V: $R_A > 10 \text{ kOhm}$

1 ... 5 V: $R_A > 5 \text{ kOhm}$

0 ... 5 V: $R_A > 5 \text{ kOhm}$

0 ... 10 V: $R_A > 10 \text{ kOhm}$

with R_A in Ohm and U_B in VDC

Dimensions in inch [mm] WU-10

Circular connector
Order code: M4

1/4" Swivel Female
Face Seal,
Order code: 72

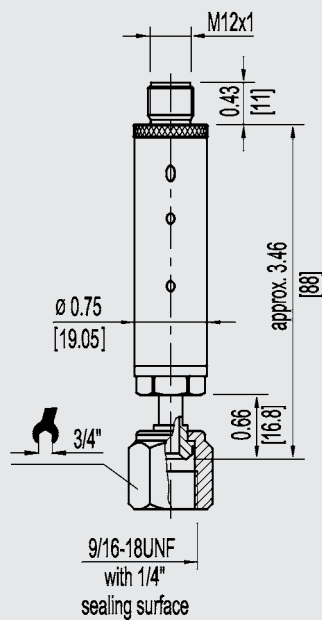

with side access (IP 54 / Nema 3S)

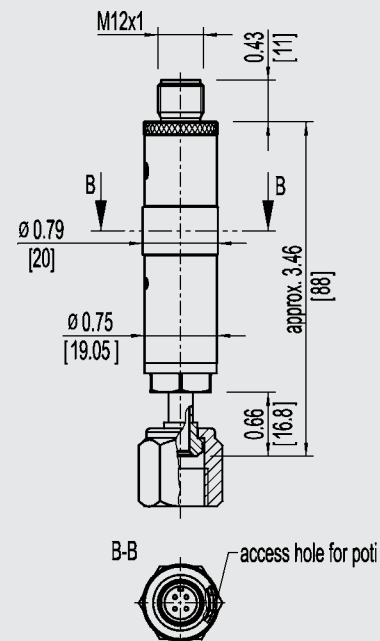

Process connection variants

1/4" Swivel Male Face Seal,
Order code: 71

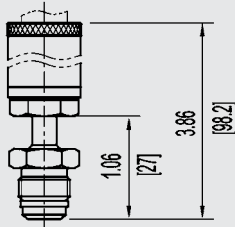

1/4" T-Connector, Weld Stub
Order code: WT

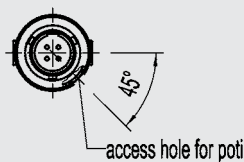
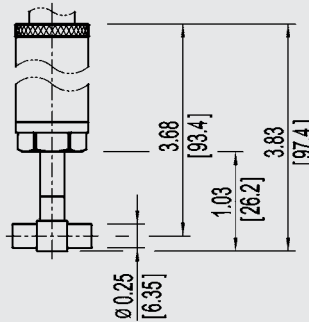

1/4" T-Connector, Weld Stub (1")
Order code: WR

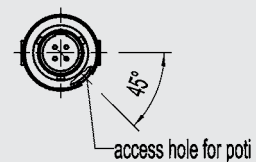
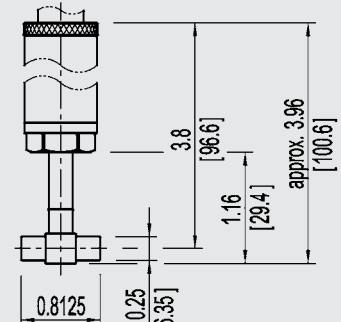

Dimensions in inch [mm] WU-15

Circular connector
Order code: M4

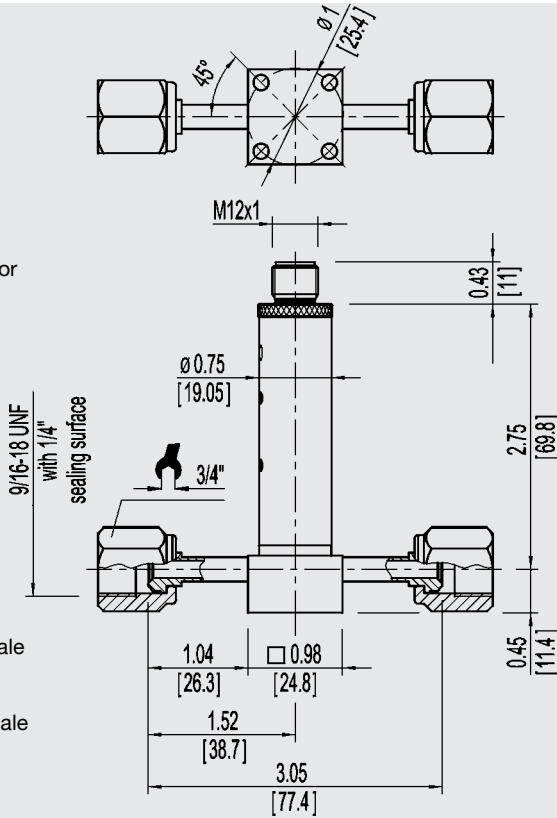

1/4" Swivel Female
Face Seal,
Order code: 72
1/4" Swivel Female
Face Seal,
Order code: 72

with side access (IP 54 / Nema 3S)

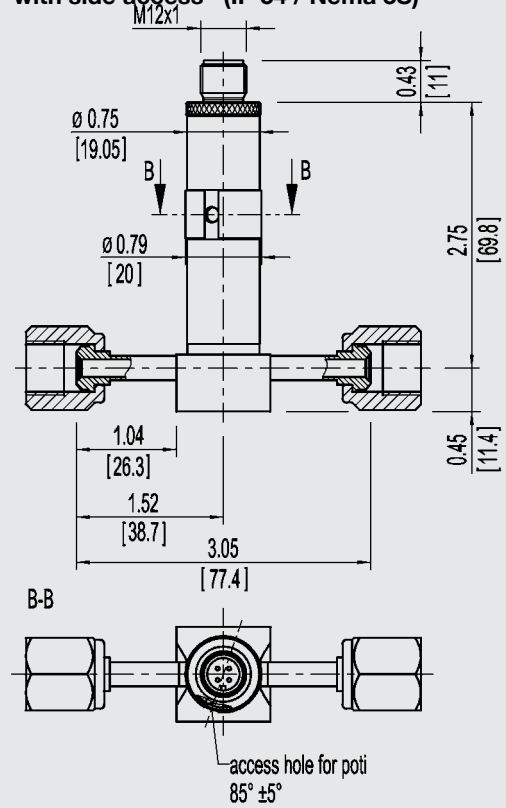

Process connection variants

1/4" Swivel Female Face Seal
Order code: 72,
1/4" Swivel Male Face Seal
Order code: 71

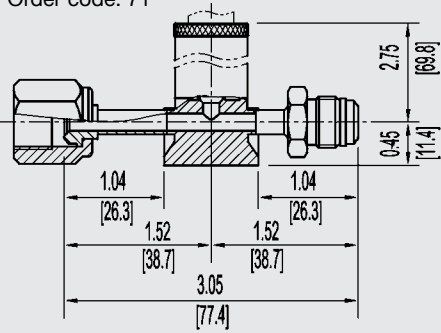

1/4" Fixed Male Face Seal
Order code: WG
1/4" Swivel Female Face Seal
Order code: 72,

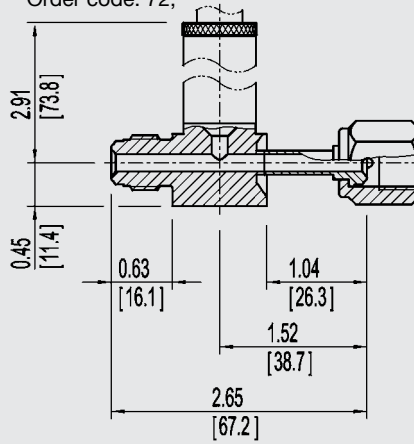

1/4" Fixed Male Face Seal, Order code: WG
1/4" Swivel Male Face Seal, Order code: 71

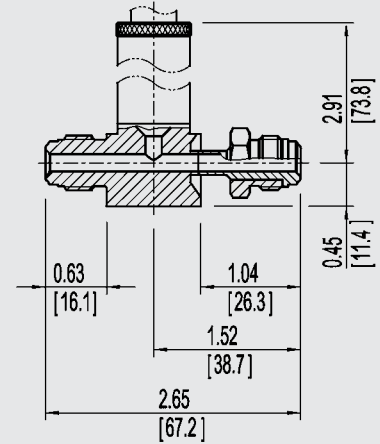

1/4" Swivel Male Face Seal, Order code: 71
1/4" Swivel Male Face Seal, Order code: 71

1/4" Weld Stub, Order code: VN
1/4" Weld Stub, Order code: VN

1/4" Fixed Male Face Seal, Order code: WG
1/4" Weld Stub, Order code: VN

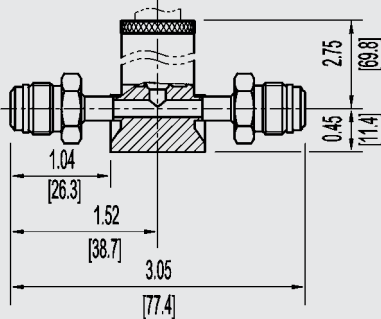

Process connection variants WU-15

1/4" Fixed Male Face Seal, Order code: WG
 1/4" Fixed Male Face Seal, Order code: WG

1/4" Fixed Male Face Seal High Flow Through, Order Code: WM
 1/4" Fixed Male Face Seal High Flow Through, Order Code: WM
 only available with pressure ranges up to 25 bar / 300 psi

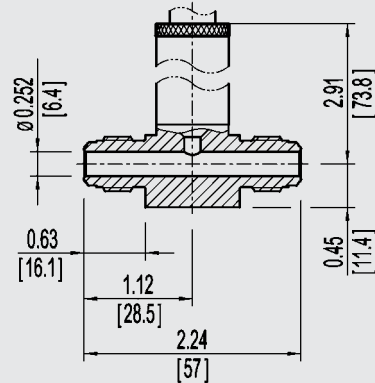
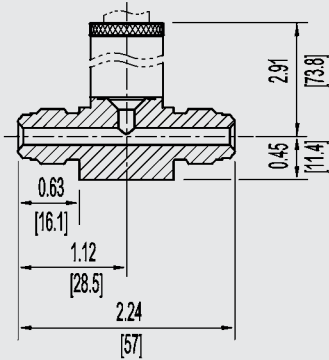

Dimensions in inch [mm] WU-16

Bayonet connector
 Order code: O4

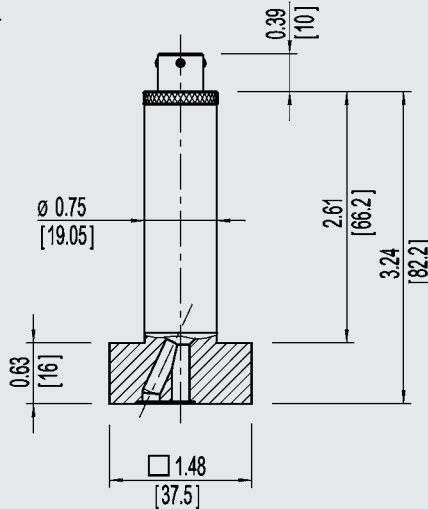

MSM C
 1 1/2" SQ,
 Order code:
 WC

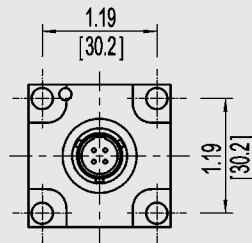

with side access (IP 54 / Nema 3S)

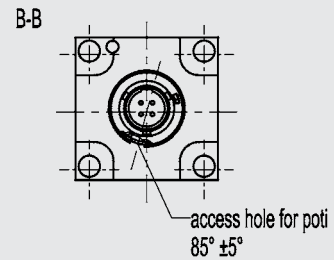
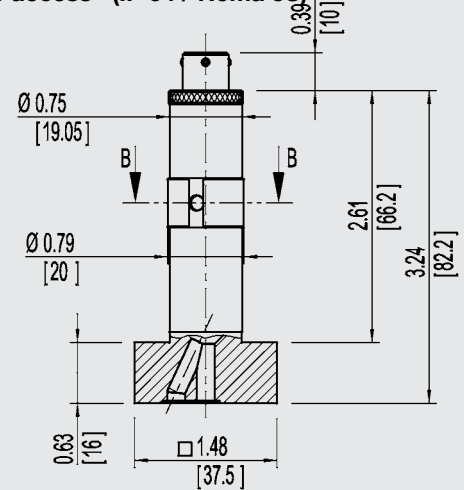

Process connection variants

MSM W 1 1/2"
 Order code: WD

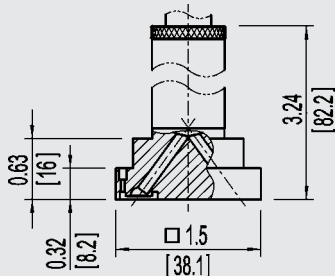

MSM C 1 1/8" SQ
 Order code: WE

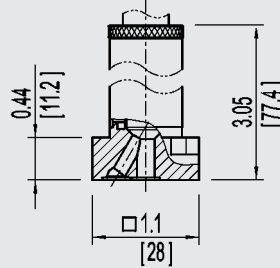

MSM W 1 1/8"
 Order code: WF

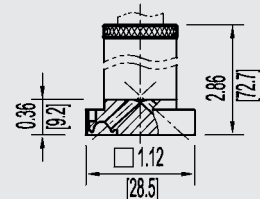

Dimensions and wiring details WU-1*

Ingress Protection IP per IEC 60 529

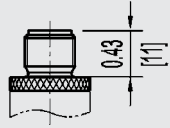
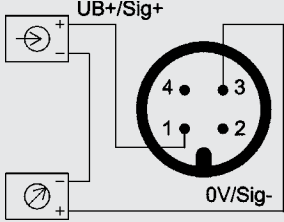
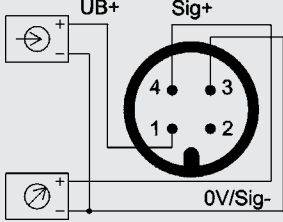
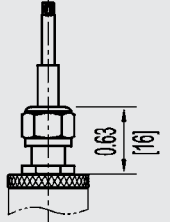
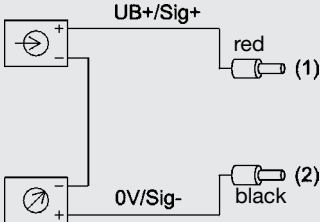
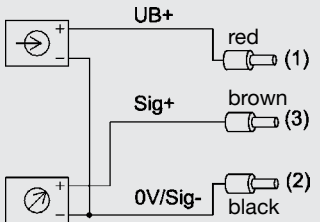
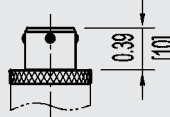
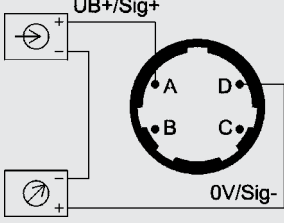
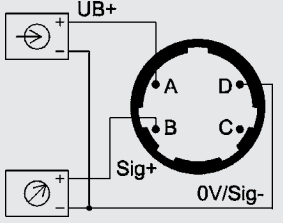
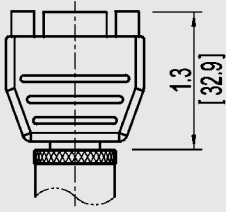
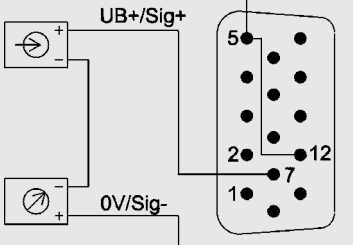
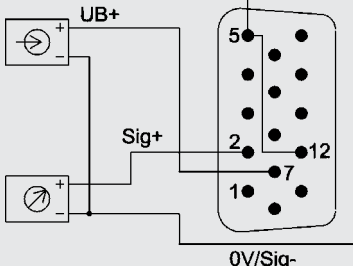
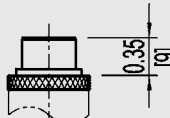
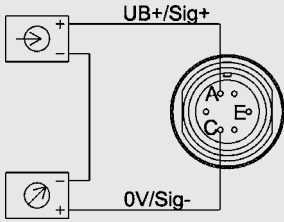
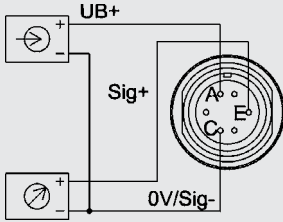
	Dimensions in inch [mm]	2-wire	3-wire
Circular connector M 12x1 4-pin, IP 65 (NEMA 4 *) Order code: M4			
Flying leads IP 65 (NEMA 4 *) Order code: DI			
Bayonet connector 4-pin, IP 65 (NEMA 4 *) Order code: O4			
SUB-D connector 15-pin, IP 54 (NEMA 3S) Order code: TX			
Circular Connector R03 6-pin, IP 54 (NEMA 3S) Order code: U6			

*) with side access IP 54 (NEMA 3S)

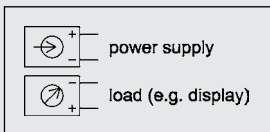

Specifications and dimensions given in this leaflet represent the state of engineering at the time of printing. Modifications may take place and materials specified may be replaced by others without prior notice.

WU-10 Smart Codes for Custom Order Configurations

Field No.	Code	Feature
1	Signal Output	
	A	4 ... 20 mA, 2-wire
	F	0 ... 10 V, 3-wire
	G	0 ... 5 V, 3-wire
2	Unit	
	B	bar
	P	psi
	?	other <i>(MPa, kPa, kgF/cm2, etc.)</i>
	3	psi absolute
3	Pressure Range	
	CH	-1 ... +3 bar ¹⁾ -30 inHg ... 100 psi
	CT	-1 ... +6 bar
	CL	-1 ... +9 bar
	CP	-1 ... +15 bar
	CQ	-1 ... +25 bar
	CX	-1 ... +40 bar -30 inHg ... 500 psi
	CY	-1 ... +60 bar
	C1	-1 ... +100 bar
	C2	-1 ... +160 bar
	C3	-1 ... +250 bar
	BG	0 ... 4 bar ¹⁾ 0 ... 160 psi
	EF	0 ... 7 bar
	BI	0 ... 10 bar 0 ... 300 psi
	BK	0 ... 16 bar
	BL	0 ... 25 bar
	BM	0 ... 40 bar
	BN	0 ... 60 bar 0 ... 1000 psi
	BO	0 ... 100 bar 0 ... 1500 psi
	BP	0 ... 160 bar 0 ... 2000 psi
	BQ	0 ... 250 bar 0 ... 3000 psi
	BS	0 ... 400 bar 0 ... 5000 psi
	CE	-30 inHg ... 45 psi ¹⁾
	CF	-30 inHg ... 60 psi ¹⁾
	CK	-30 inHg ... 160 psi
	CI	-30 inHg ... 250 psi
	CM	-30 inHg ... 300 psi
	BE	0 ... 60 psi ¹⁾
	BF	0 ... 100 psi
	DG	0 ... 250 psi
	DI	0 ... 500 psi
	??	other

WU-10 Smart Codes for Custom Order Configurations (continued)

Field No.	Code	Feature
Process Connection		
	WR	1/4" T-connector (1" version)
	71	Original VCR-male nut SS4-VCR-4 (FSM)
	72	Original VCR-union nut SS4-VCR-1 (FSF)
4	??	other
Dampening		
	Z	Without
	?	other
	A	>100 ms
5	B	>100 ms (FM approved)
Electrical connection		
	M4	4-pin locking plug M12 x 1
	DI	flying lead, IP 65
	O4	4-pin bayonet connector (Bendix)
6	??	other
Cable Length		
	Z	Without <i>always choose if plug version</i>
	C	1.5 m
	E	3 m
7	?	other
Special Design Features		
	Z	Without
8	1	Zero potentiometer with side access <i>always choose with dampening</i>
Additional Order Info		
9	1	quality certificate
10	T	additional text

1) Accuracy 1.0% of span

Order Code: 1 2 3 4 5 6 7 8 9 10 *

WU-10 - - - - **B G** - **Z**

*Additional order details _____

WU-15 Smart Codes for Custom Order Configurations

Field No.	Code	Feature
1	Signal Output	
	A	4 ... 20 mA, 2-wire
	F	0 ... 10 V, 3-wire
	G	0 ... 5 V, 3-wire
2	Unit	
	B	bar
	P	psi
	?	other <i>(MPa, kPa, kg/cm², etc.)</i>
	3	psi absolute
3	Range	
	CH	-1 ... +3 bar 1) -30 inHg ... 100 psi
	CT	-1 ... +6 bar
	CL	-1 ... +9 bar
	CP	-1 ... +15 bar
	CQ	-1 ... +25 bar
	CX	-1 ... +40 bar -30 inHg ... 500 psi
	CY	-1 ... +60 bar
	C1	-1 ... +100 bar
	C2	-1 ... +160 bar
	C3	-1 ... +250 bar
	BG	0 ... 4 bar 1) 0 ... 160 psi
	EF	0 ... 7 bar
	BI	0 ... 10 bar 0 ... 300 psi
	BK	0 ... 16 bar
	BL	0 ... 25 bar
	BM	0 ... 40 bar
	BN	0 ... 60 bar 0 ... 1000 psi
	BO	0 ... 100 bar 0 ... 1500 psi
	BP	0 ... 160 bar 0 ... 2000 psi
	BQ	0 ... 250 bar 0 ... 3000 psi
	BS	0 ... 400 bar 0 ... 5000 psi
	CE	-30 inHg ... 45 psi 1)
	CF	-30 inHg ... 60 psi 1)
	CK	-30 inHg ... 160 psi
	CI	-30 inHg ... 250 psi
	CM	-30 inHg ... 300 psi
	BE	0 ... 60 psi 1)
	BF	0 ... 100 psi
	DG	0 ... 250 psi
	DI	0 ... 500 psi
	??	other

WU-15 Smart Codes for Custom Order Configurations (continued)

Field No.	Code	Feature	
Process Connection			
4	WG	1/4" fixed male face seal	
	WM	1/4" fixed male face seal, high flow	
	71	Original VCR-male nut SS4-VCR-4 (FSM)	
	72	Original VCR-union nut SS4-VCR-1 (FSF)	
	??	other	
Outlet Process Connection			
5	VN	1/4" weld stub	
	WG	1/4" fixed male face seal	
	WM	1/4" fixed male face seal, high flow through	
	71	Original VCR-male nut SS4-VCR-4	
	72	Original VCR-union nut SS4-VCR-1	
	??	other	
Dampening			
6	Z	Without	
	?	other	
	A	>100 ms	
	B	>100 ms (FM approved)	
Electrical Connection			
7	M4	4-pin locking plug M12 x 1	
	DI	flying lead, IP 65	
	O4	4-pin bayonet connector (Bendix)	
	??	other	
Cable Length			
8	Z	N\C <i>always choose if plug version</i>	
	C	1.5 m	
	E	3 m	
	?	other	
Special Design Features			
9	Z	Without	
	1	Zero potentiometer with side access	
Additional order info			
10	YES	NO	
	1	Z	quality certificates
11	T	Z	additional text

1) Accuracy 1.0% of span

Order Code: 1 2 3 4 5 6 7 8 9 10 11*

WU-15 - - - - **B G** - **Z**

*Additional order details _____

WU-16 Smart Codes for Custom Order Configurations (continued)

Field No.	Code	Feature	
6	Cable length		
	Z	without always choose if plug version	
	C	1.5 m	
	E	3 m	
	?	other	
7	Special design features		
	Z	without	
	1	Zero potentiometer with side access	
8	Additional order info		
	YES	NO	
	1	Z	quality certificates
9	T	Z	additional text

1) Accuracy 1.0% of span

Order Code: 1 2 3 4 5 6 7 8 9*

WU-16 - - - - **7 B G** - **Z**

*Additional order details _____

Specifications and dimensions given in this leaflet represent the state of engineering at the time of printing. Modifications may take place and materials specified may be replaced by others without prior notice.



WIKAL Instrument Corporation
 1000 Wiegand Boulevard
 Lawrenceville, GA 30043
 Tel (770) 513-8200 Toll-free 1-888-WIKA-USA
 Fax (770) 338-5118
 E-Mail info@wika.com
 www.wika.com