

Bourdon Tube Pressure Gauges High Purity Series Type 130.15

WIKA Datasheet 130.15

Applications

- Semiconductor and electronic industry, medical industry, gene technology, biotechnology and pharmaceutical industries.
- Suitable for corrosive environments and gaseous or liquid media that will not obstruct the pressure system
- Where measurement of high purity gases is needed without contamination of the process media.

Special Features

- 316L wetted parts
- Electro-polished stainless steel case & face-seal connection
- Positive and compound pressure ranges to 10,000 psi

Standard Features

Design

ASME B40.100

Sizes

2" (53 mm)
1 1/2" (40 mm)

Accuracy Class

2": $\pm 2/1/2\%$ of span (ASME B40.100 Grade A)
1 1/2": $\pm 3/2/3\%$ of span (ASME B40.100 Grade B)

Ranges

Vacuum / compound to 30"Hg/0/200 psi
Pressure from 0 psi up to 6000 psi
or other equivalent units of pressure or vacuum

Working Pressure

Steady: $\frac{3}{4}$ full-scale value
Fluctuating: $\frac{2}{3}$ full-scale value
Short time: full-scale value

Operating Temperature

Ambient: -40°F to +140°F (-40°C to +60°C)
Medium: +212°F (+100°C) maximum



Bourdon Tube Pressure Gauge Model 130.15

Temperature Error

Additional error when temperature changes from reference temperature of 68°F (20°C) $\pm 0.4\%$ for every 18°F (10°C) rising or falling. Percentage of span.

Weather Protection

Weather resistant (NEMA 3 / IP 54)

Pressure Connection

Material: 316L SS
Position: Lower mount (LM) & center back mount (CBM)
Type of connection: 1/4" NPT - male
Wetted surface finish: $R_a < 1.0\mu\text{m}$ ($R_a < 40\mu\text{inch}$)-internal

Bourdon Tube

Material: 316L SS
30"Hg (vac) to 1,000 psi, C-type
1,500 to 6000 psi, helical type
Helium leak tested 1×10^{-9} scc/sec (inboard)

Socket

Material: 316L SS
 $R_a < 1.0\mu\text{m}$ ($R_a < 40\mu\text{inch}$) - internal

(Standard Features continued on Page 2 of 5)

Movement

Stainless steel

Dial

White aluminum with stop pin and black lettering

Pointer

Black aluminum

Case

304 SS, electropolished

Window

Polycarbonate: twist-lock (2"); snap cap (1½")

Cleanliness

ASME B40.1 Level IV (for oxygen service)

Packaged in single nylon bag

Purged with Nitrogen

Protective cap over threaded connection

Order Options (minimum order may apply)

Alarm contact (830.1E), inductive

Packaged in two bags

Other special connections limited to wrench flat area

Custom dial layout

Stainless steel restrictor

Particle test with certificate

Dual pressure scales

Additional process wetted materials available per request

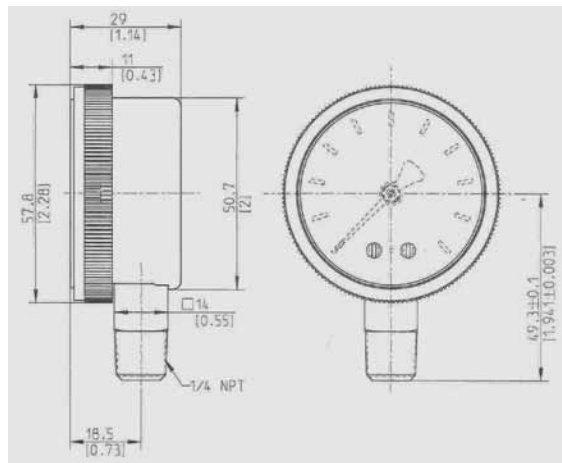

130.15 2" LM
¼" NPT-MALE (NPTM)

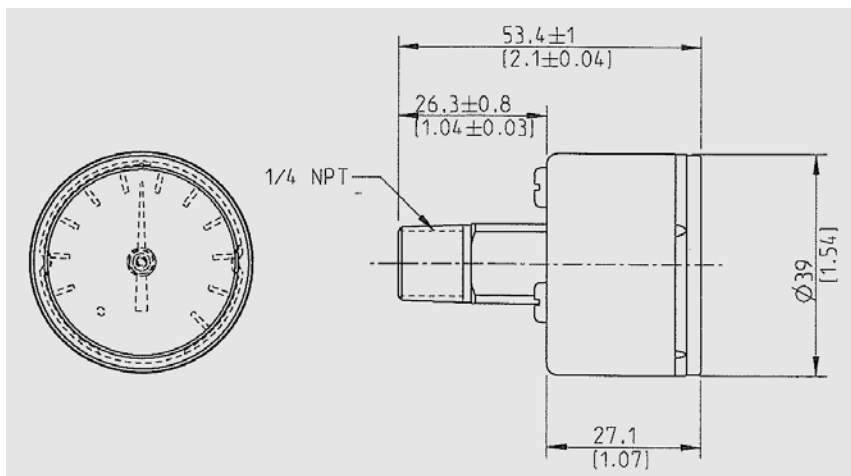

130.15 1½" CBM
¼" NPT-MALE (NPTM)

Dimensions

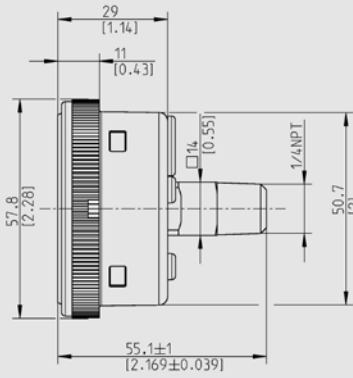

**130.15 2" CBM
1/4" NPT-MALE (NPTM)**

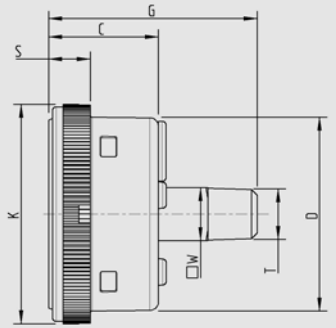

**130.15 2" CBM
1/4" NPT-MALE (NPTM)**

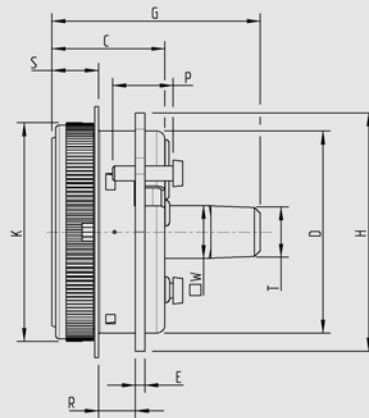
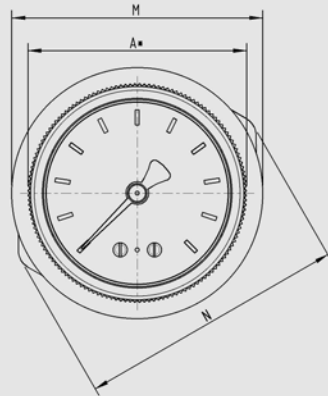

**130.15 2" CBM w/U-CLAMP
1/4" NPT-MALE (NPTM)**

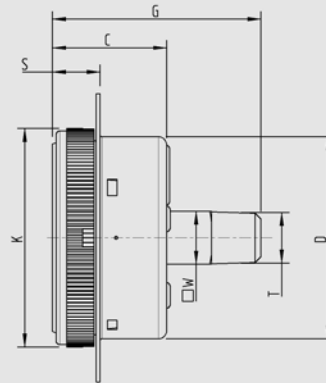
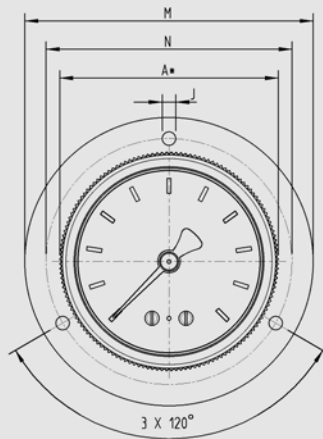

**130.15 2" CBM w/ FRONT FLANGE
1/4" NPT-MALE (NPTM)**

SIZE		A*	C	D	E	G	H	K	M	N	P	R	S	T	W
2"	MM	50	30.2	53.4	2.5	55.1	63	57.8	66.4	71	16	9.8	12.6	1/4"	14
	IN	2	1.19	2.10	0.10	2.17	2.48	2.28	2.61	2.80	0.63	0.39	0.50		.55

Case	304 SS, electropolished
Wetted Material	316L SS
Window	Polycarbonate
Dial	Aluminum, white with stop pin
Pointer	Aluminum black
Accuracy	2" +/- 2/1/2% of span (ASME B40.1 Grade A) 1 1/2" +/- 2/3/2% of span (ASME B40.1 Grade B)
Cleanliness	ASME B40.1 Level IV (for oxygen service)
Packaging	Single nylon bag, nitrogen purged

Field No.	Code	Feature
1	Nominal Case Size	
	6	1.5" (40 mm)
	7	2.0" (50 mm)
2	Unit	
	P	psi
	B	bar
	L	kPa
	E	MPa
	K	Kg/cm2
	?	other
3	Pressure Range	
	V310	-30 inHg ... 0 psi
	V321	-30 inHg ... 15 psi
	V331	-30 inHg ... 30 psi
	V352	-30 inHg ... 60 psi
	V379	-30 inHg ... 100 psi
	V412	-30 inHg ... 160 psi
	V415	-30 inHg ... 200 psi
	V422	-30 inHg ... 300 psi
	G310	0 ... 15 psi
	G321	0 ... 30 psi
	G341	0 ... 60 psi
	G369	0 ... 100 psi
	G411	0 ... 160 psi
	G414	0 ... 200 psi
	G421	0 ... 300 psi
	G428	0 ... 400 psi
	G441	0 ... 600 psi
	G455	0 ... 800 psi
	G469	0 ... 1000 psi
	G510	0 ... 1550 psi
	G514	0 ... 2000 psi
	G521	0 ... 3000 psi
	G528	0 ... 4000 psi
	G541	0 ... 6000 psi
	????	other - please specify
	4	Unit
Z		without
P		psi
B		bar
L		kPa
E		MPa
K		Kg/cm2
?	other	

Field No.	Code	Feature
Process Connection		
5	NB	1/4" NPT - male
	??	other - please specify
Connector Position		
6	B	Center back mount
	U	Lower mount
Mounting Flange/Bracket		
7	Z	Without
	K	Panel mount with SS mounting bracket (2" CBM only)
	F	Front flange, polished SS (2" CBM only)
Switch Type		
8	Z	without
	N	Inductive NPN (2" case only) 830.1E
	P	Inductive PNP (2" case only) 830.1E
Electrical Connection		
9	ZZ	without
	DA	Flying leads, 10' (3 meters)
Quality Certificates		
10	?	other - please specify
Additional Order Details		
11	Z	without
	T	Additional text

Order Code: 1 2 3 4 5 6 7 8 9 10 11*

130.15 - - - - - **Z**

*Additional order details _____

Specifications provided in this datasheet represent the state of engineering at the time of printing.
Modifications may take place and the specified materials may change without prior notice



WIKAI Instrument Corporation
1000 Wiegand Boulevard
Lawrenceville, GA 30043-5868
Tel: 888-WIKA-USA • 770-513-8200
Fax: 678-739-2569
E-Mail: UHP@wika.com
www.wika.com/UHP