



# Differential Pressure Gauges for Low Pressure Measurements Capsule Element Series • Type 716.11

## Pressure Gauges

### Application

Differential pressure measurement of clean and dry low pressure gases

### Sizes

2½", 4" and 6" (63, 100 and 160 mm)

### Accuracy

±1.5% of span

### Ranges

2½": 6 to 160 "H<sub>2</sub>O (16 to 400 mbar)  
4": 2.5 to 100 "H<sub>2</sub>O (6 to 250 mbar)  
6": 1.5 to 100 "H<sub>2</sub>O (4 to 250 mbar)  
or equivalent other units of pressure or vacuum

### Working Range

Steady: full scale value  
Fluctuating: 0.9 x full scale value

### Overpressure Safety

No overpressure safety when pressure is only applied to one side

### Static Pressure Rating

2½": 160 "H<sub>2</sub>O (400 mbar)  
4" & 6": 100 "H<sub>2</sub>O (250mbar)

### Operating Temperature

Ambient: -4°F (-20°C) to 140°F (60°C)  
Media: max. + 158°F (+70°C)

### Temperature error

Additional error when temperature changes from reference temperature of 68°F (20°C) ± 0.4% for every 18°F (10°C) rising or falling. Percentage of span.

### Weather Protection

Weather tight (NEMA 3 / IP 54)

## Standard Features

### Connection (exposed to pressure medium)

Copper alloy  
Lower mount - parallel, one behind the other  
2½": 2 x 1/8" NPT or G 1/8 A, 14 mm flats  
4" & 6": 2 x 1/2" NPT or G 1/2 A, 22 mm flats

### Capsule Element (exposed to pressure medium)

Copper alloy

### Movement (exposed to pressure medium)

Copper alloy

### Dial (exposed to pressure medium)

White aluminum with black lettering

### Pointer(exposed to pressure medium)

Black aluminum

### Zero adjustment (exposed to pressure medium)

Hole in window allows access to zero adjustment screw on dial.



### Case (exposed to pressure medium)

Stainless steel with stainless steel bayonet ring. 4" & 6" with blow-out plug in back of case

### Window (exposed to pressure medium)

Acrylic

### Gaskets (exposed to pressure medium)

Buna rubber (NBR) and silicone rubber

### Gauge Mounting

Pressure inputs identified ⊕ and ⊖

⊕ high pressure

⊖ low pressure

Front flange or rear flange available

Optional pipe mounting pressure gauge support also available

### Order Options

Other threaded pressure connection

Front flange or rear flange

Pipe mounting pressure gauge support (see data sheet AAM 09.07)

Pressure equalizing valve (see data sheet AAM 09.11)

Back mount

Overpressure safety of high pressure side:

3 X with scale ranges 1.5 to 10 "H<sub>2</sub>O (4 to 25 mbar)

10 X with scale ranges 16 to 160 "H<sub>2</sub>O (40 to 400 mbar)

Contact factory for overpressure safety of low pressure side

**APM 716.11**  
**(APM 07.07)**

**Dimensions:**

Lower mount

Optional back mount

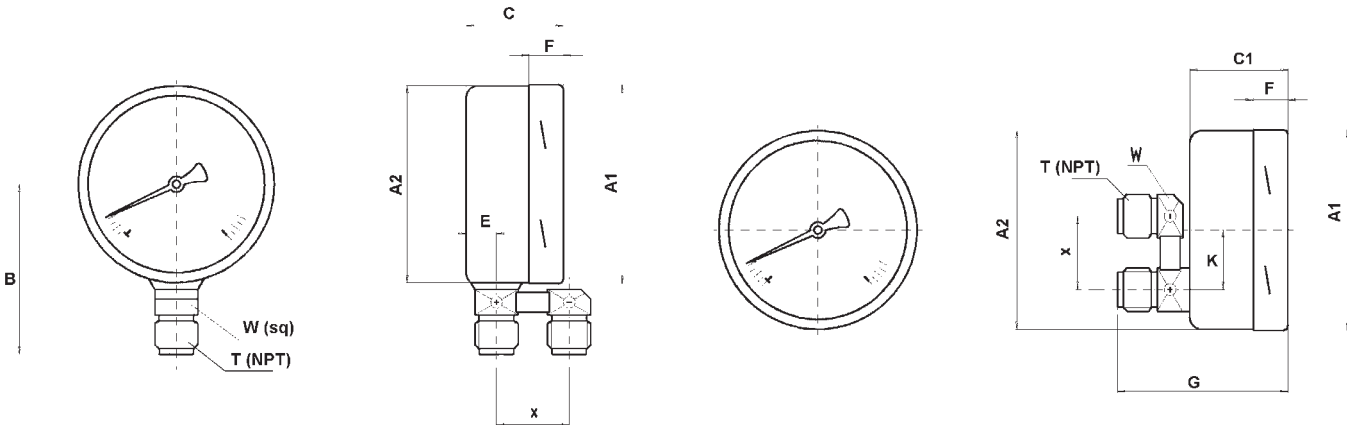

TYPE	WEIGHT	KEY	A1	A2	B	C	C1	E	F	G	K	T	W	X
716.11 2.5"	0.51 lb	mm	64	62	49	48.5	38	11	13.5	55	20	1/8"	14	23
		in	2.52	2.44	1.93	1.91	1.50	.43	.53	2.16	.79		.55	.91
716.11 4"	1.61 lb	mm	101	99	87	48.5	49.5	15.5	17.5	84	30	1/2"	22	37
		in	3.98	3.9	3.43	1.91	1.95	.61	.69	3.31	1.18		.87	1.46
716.11 6"	2.93 lb	mm	161	159	118	48.5	51.5	15.5	17.5	87	50	1/2"	22	37
		in	6.33	6.25	4.65	1.91	2.03	.61	.69	3.43	1.97		.87	1.46

**Design and Operating Principle**

- The case contains the capsule pressure element.
- High pressure (+) is applied to the capsule.
- Low pressure (-) is applied to the inside of the case
- Any pressure differential between high pressure and low pressure side will deflect the capsule pressure element
- The deflection is indicated on the dial by a pointer.

THE MEASURE OF  
**Total Performance™**

**Ordering Information:**

State computer part number (if available) / type number / size / range / connection size and location / options required.

Specifications given in this price list represent the state of engineering at the time of printing. Modifications may take place and the specified materials may change without prior notice



**WIKAI Instrument Corporation**

1000 Wiegand Boulevard

Lawrenceville, Georgia 30043-5868

Tel: 770-513-8200 Fax: 770-338-5118

http://www.wika.com e-mail: info@wika.com