

OEM Pressure Transmitter Model ECO-1

WIKA Data Sheet ECO-1

Applications

- Hydraulics and pneumatics
- Mechanical engineering
- General industrial applications

Special Features

- Pressure ranges from 0-15PSI to 0...15,000PSI
- 4-20 mA 2-wire and 0-10V 3-wire output signals available from stock
- Stainless steel case and wetted parts

Description

WIKA ECO-Tronic pressure transmitters are engineered to fit many industrial pressure measurement applications. Typical applications include hydraulics and pneumatics, compressor controls, pump protection, refrigeration and air conditioning systems.

Reliable Operation

The ECO Tronic features an all-welded stainless steel measuring cell for improved media compatibility. There are no internal soft sealing materials that may react with the media or deteriorate over time. The case is also made of stainless steel and is available with environmental protection ratings up to NEMA 4 / IP 67.

Pressure ranges from 15PSI to 15,000PSI meet the requirements of most industrial pressure sensing applications. Pressure ranges up to 300PSI use a piezoresistive measuring cell. The higher pressure ranges use thin film sensor technology.



Left: ECO-1 with DIN connection
Right: ECO-1 with cable option

Standard signal outputs of 4-20 mA and 0-10V allow the ECO-Tronic to be integrated into many existing applications. Excellent RFI and EMI resistance protect the output signal integrity under difficult operating conditions.

Each ECO-Tronic undergoes extensive quality control testing and calibration to achieve an accuracy of $\leq 0.50\%$ full scale. The printed circuit boards use state-of-the-art surface mount technology. Each is individually temperature compensated to assure accuracy and long-term stability even when exposed to severe ambient temperature variations.

Specifications

Model ECO-1

Pressure range	15PSI	25PSI	50PSI	60PSI	100PSI	200PSI	300PSI	500PSI	750PSI
Maximum pressure*	72PSI	72PSI	140PSI	240PSI	240PSI	500PSI	500PSI	1160PSI	1740PSI
Burst pressure**	87PSI	87PSI	170PSI	290PSI	290PSI	600PSI	600PSI	5800PSI	7970PSI
Pressure range	1000PSI	1500PSI	2000PSI	3000PSI	5000PSI	7500PSI	10,000PSI	15,000PSI	
Maximum pressure*	2900PSI	4640PSI	4640PSI	7250PSI	11,600PSI	17,400PSI	21,750PSI	21,750PSI	
Burst pressure**	11,600PSI	14,500PSI	14,500PSI	17,400PSI	24,650PSI	34,800PSI	43,500PSI	43,500PSI	

{Absolute pressure ranges available to 300 PSIA}

*Pressure applied up to the maximum rating will cause no permanent change in specifications but may lead to zero and span shifts

**Exceeding the burst pressure may result in destruction of the transmitter and possible loss of media

Materials			
■ Wetted parts		Stainless steel	
■ Case		Stainless steel	
Internal transmission fluid		Synthetic oil only for pressure ranges up to 300 PSI {Halocarbon oil for oxygen applications} ^{*)}	
Power supply U _B	DC V	10 < U _B ≤ 30 (14 ... 30 with output signal 0 ... 10 V, 1 ... 6 V)	
Signal output and Maximum load R _A		4 ... 20 mA, 2- wire	R _A ≤ (U _B - 10 V) / 0.02 A with R _A in Ohm and U _B in Volt
		0 ... 10 V, 3- wire	R _A > 10 kOhm
		1 ... 5 V, 3- wire	R _A > 5 kOhm
		1 ... 6 V, 3- wire	R _A > 6 kOhm
Response time (10 ... 90 %)	ms	≤ 5 (≤ 10 ms at medium temperature < -30 °C for pressure ranges up to 300 PSI)	
Accuracy ^{**)}	% of span	≤ 1.0 (limit point calibration)	
	% of span	≤ 0.5 (BFSL)	
Repeatability	% of span	≤ 0.1	
1-year stability	% of span	≤ 0.3 (at reference conditions)	
Permissible temperature of			
■ Medium		-40 ... +212 °F	-40 ... +100 °C
■ Ambient		-22 ... +176 °F	-30 ... + 80 °C
■ Storage		-22 ... +212 °F	-30 ... +100 °C
Compensated temp range		32 ... + 176 °F	0 ... + 80 °C
Temperature coefficients (TC) within compensated temperature range			
■ Mean TC of zero	% of span	≤ 0.4 / 10 K	
■ Mean TC of range	% of span	≤ 0.3 / 10 K	
CE conformity		89/336/EEG interference emission and immunity see EN 61 326 97/23/EG Pressure equipment directive	
Wiring protection		Protected against reverse polarity, overvoltage and short circuit	
Ingress protection per Weight	lb	IEC 60 529 / EN 60 529, see page 3 Approx. .33	

*) Media temperature for oxygen version : -22 ... 140 °F (-30 ... +60 °C)

**) Accuracy statement includes linearity, hysteresis and repeatability.
Limit point calibration performed in vertical mounting position with pressure connection facing down.

{ } Items in curved brackets are optional extras for additional cost.

Dimensions in inches (mm)

L-connector
DIN EN 175301-803, (DIN 43 650)
IP 65
Order code: A4

Circular connector
M 12x1, 4-pin
IP65
Order code: M4

Cable with free ends
NEMA 4 / IP67
Order code: DL

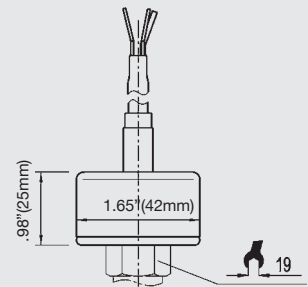
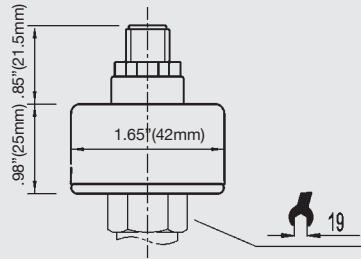
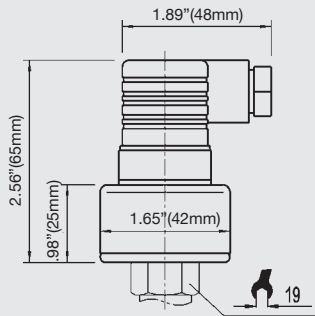

Pressure connections

1/4 NPT male
Order code: NB

G 1/4
EN 837
Order code: GB

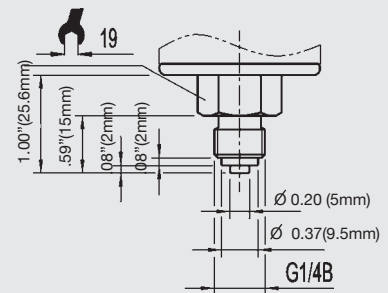
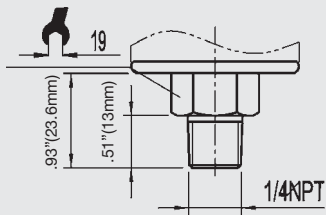

Wiring

2-wire system

3-wire system

L-connector

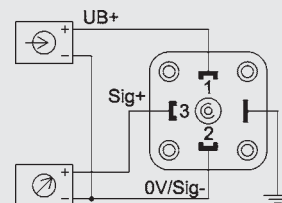
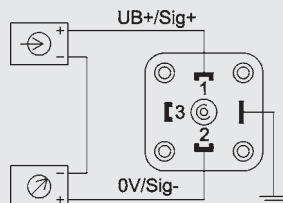

Circular connector
M 12x1 4-pin

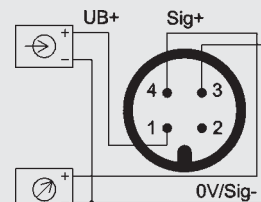
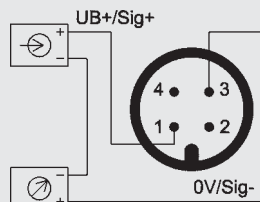

cable with free ends

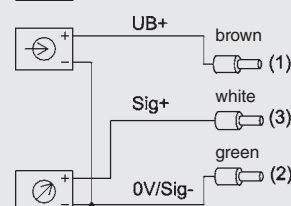
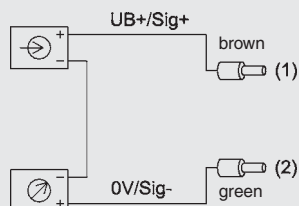

Legend:

	power supply	Sig+ output signal positive
	load (e.g. display)	UB+ power supply positive
		0V power supply negative
		Sig- output signal negative

This page intentionally left blank.

Specifications and dimensions given in this data sheet represent the state of engineering at the time of printing.
Modifications may take place and materials specified may be replaced by others without prior notice.



WIKAI Instrument Corporation
1000 Wiegand Boulevard
Lawrenceville, GA 30043
1-888-WIKA-USA /770-513-8200 (in GA)
Fax 770-338-5118
info@wika.com www.wika.com