

Bourdon Tube Pressure Gauge Model 21X.54 Stainless Steel Construction

WIKA Datasheet 21X.54

Applications

- Intended for adverse service conditions where pulsating or vibration exists
- Process industry
- Suitable for gaseous or liquid media that will not obstruct the pressure system

Special features

- Vibration and shock resistant (with liquid filling)
- Stainless steel case with removable bayonet ring
- Pressure ranges up to 15,000 psi

Standard Features

Design

ASME B40.100 & EN 837-1

Sizes

2½" & 4" (63 & 100 mm)

Accuracy class

2½": ± 2/1/2% of span (ASME B40.100 Grade A)

4": ± 1% of span (ASME B40.100 Grade 1A)

Ranges

Vacuum / Compound to 200 psi

Pressure from 15 psi to 15,000 psi

or other equivalent units of pressure or vacuum

Working pressure

2½": Steady: 3/4 scale value
 Fluctuating: 2/3 full scale value
 Short time: full scale value

4": Steady: full scale value
 Fluctuating: 0.9 x full scale value
 Short time: 1.3 x full scale value

Operating temperature

Ambient: -40°F to +140°F (-40°C to +60°C) - dry
 -4°F to +140°F (-20°C to +60°C) - glycerine filled
 -40°F to +140°F (-40°C to +60°C) - silicone filled

Medium: +140°F (+60°C) maximum



Bourdon Tube Pressure Gauge Model 21X.54

Temperature error

Additional error when temperature changes from reference temperature of 68°F (20°C) ±0.4% for every 18°F (10°C) rising or falling. Percentage of span.

Weather protection

Weather tight (NEMA 4X / IP 65)

Pressure connection

Material: copper alloy

Lower mount (LM) or center back mount (CBM) - 2½"

Lower mount (LM) or lower back mount (LBM) - 4"

1/4" NPT or 1/2" NPT limited to wrench flat area

Bourdon tube

2½" Size- Material: Copper alloy

30" Hg (VAC) to 800 PSI- C-type (soldered)

1000PSI to 15,000PSI- helical type (soldered)

Changes to stainless steel at 7,500 PSI brazed

4" Size- Material: Copper alloy ≤ 1,000 PSI

316 stainless steel ≥ 1,500 PSI

30" Hg (Vac) to 1,000 PSI- C-type (soldered)

1,500 PSI to 15,000 PSI- helical type (brazed)

Changes to stainless steel at 1,500 PSI

Movement

Copper alloy

Dial

White aluminum with black lettering; 2½" size with stop pin

Pointer

Black aluminum, adjustable

Case

304 stainless steel with vent plug and stainless steel crimp ring. Suitable for liquid filling. Case connection sealed with EPDM o-ring (glycerine) or Viton o-ring (dry, silicone).

Window

Laminated safety glass with Buna-N gasket

Case fill

Glycerine 99.7% - Type 213.54

Optional extras

- Brass restrictor
- Stainless steel front or rear flange
- Zinc-plated steel or SS u-clamp bracket (field installable)
- Red drag pointer or mark pointer
- Silicone or fluorolube case filling
- Special connections limited to wrench flat area
- Custom dial layout
- Other pressure scales available
bar, kPa, MPa, kg/cm² and dual scales

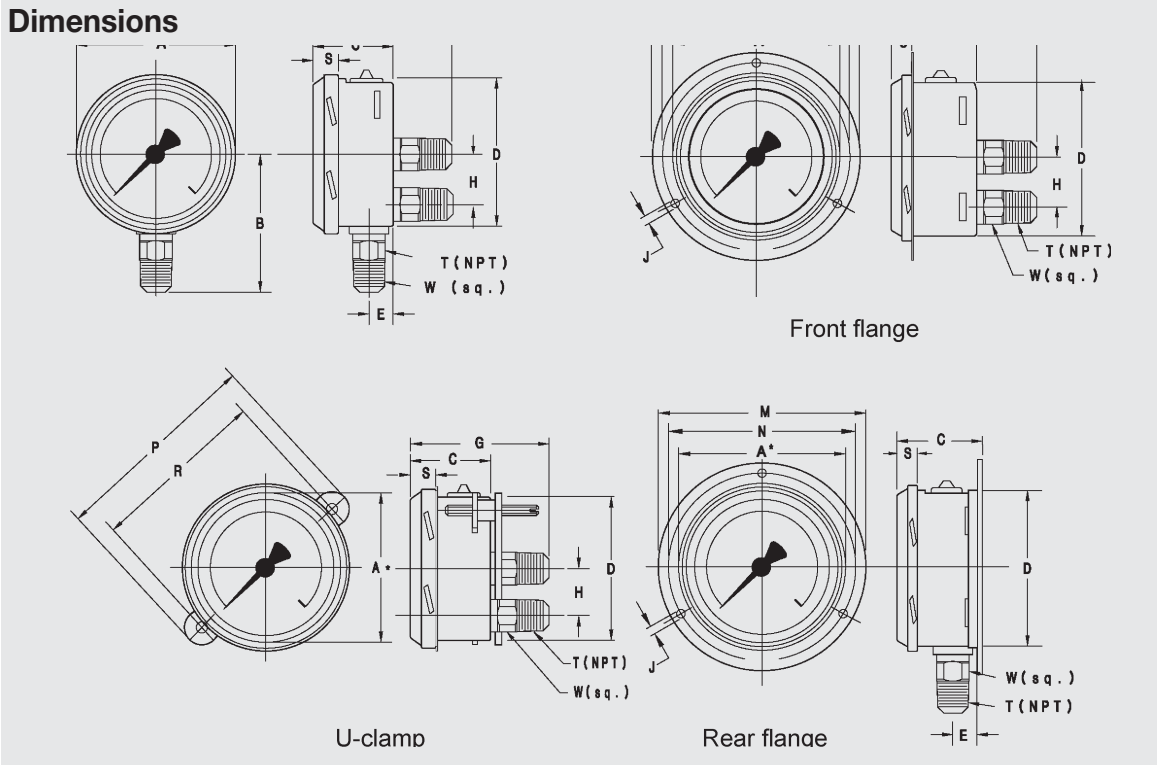

Size		A	B	C	D	E	G	H	J	M	N	P	R	S	T	W	Weight
2.5"	mm	70	54	33.5	62	13	55.5	-	3.6	85	75	87	72	12		14	0.36 lb. dry
	in	2.75	2.13	1.32	2.44	0.51	2.19	-	0.14	3.35	2.95	3.43	2.83	0.47	1/4"	0.55	0.44 lb. filled
4"	mm	110	87	49.5	100	15.5	81	30	4.8	132	116	125	110	15		22	1.10 lb. dry
	in	4.30	3.43	1.95	3.94	0.61	3.19	1.18	0.19	5.20	4.57	4.92	4.33	0.59	1/2"	0.87	1.76 lb. filled

Note: For 1/4" NPT connections on 4" gauges, reduce B dimension by 5mm/0.2"

Recommended panel cut-out:

2" U-clamp: 63mm
front flange: 63mm

4" U-clamp: 101mm
front flange: 101mm

4 1/2" panel mount adapter 104mm minimum (not shown)

Ordering information

Pressure gauge model / Nominal size / Scale range / Size of connection / Optional extras required
Specifications and dimensions given in this leaflet represent the state of engineering at the time of printing.
Modifications may take place and materials specified may be replaced by others without prior notice.



WIKAL Instrument Corporation
1000 Wiegand Boulevard
Lawrenceville, GA 30045
Tel (770) 513-8200 Toll-free 1-888-WIKA-USA
Fax (770) 338-5118
E-Mail info@wika.com
www.wika.com